



UBX-G5010, UBX-G5000

u-blox 5 GPS Chip

Mobile Terminal Applications

Preliminary Data

Overview

The u-blox 5 chip family is the latest GPS technology generation from u-blox that redefines the boundaries of GPS performance, integration and cost efficiency.



A dedicated acquisition engine with over 1 million effective correlators is capable of massively parallel searches across the time/frequency space. This enables satellite acquisition in under 1 second and acquisition sensitivity reaching -160 dBm. Acquired satellites are passed on to a power-optimized correlator engine. This setup simultaneously allows the tracking of 16 satellites and the search for additional ones. The computed position is available within seconds.

The on-chip power management unit features a switch-mode DC/DC converter that optimizes power efficiency and enables having a single voltage source. Power needs lower than 50 mW ensure long battery times.

u-blox 5 receivers will be capable, via a simple upgrade, of receiving and processing L1 Galileo signals once they become available. The ability to perceive Galileo satellites will bring higher coverage, improved reliability and better accuracy.

Its advanced jamming suppression mechanism automatically filters signals from interfering sources, thus maintaining high GPS performance.

Block Diagram

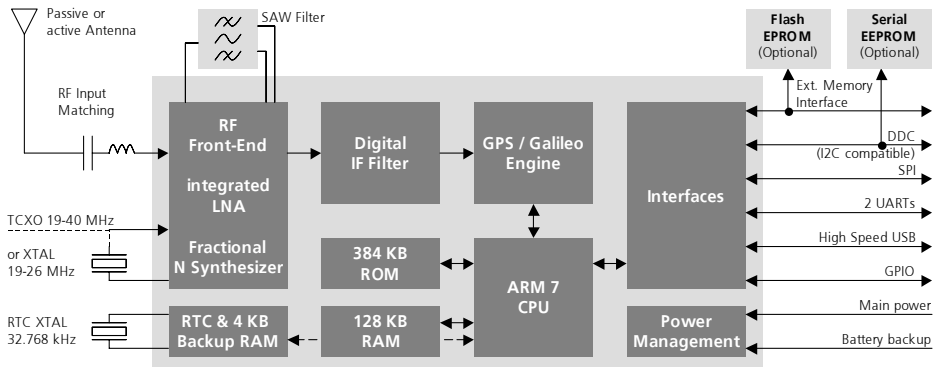

Highlights

- **Massively parallel GPS engine**
 - 50 channels
 - Over 1 million correlators
- **Cost and space efficiency**
 - Optimized silicon architecture
 - Miniature footprint
 - Small bill of material
 - No external LNA and Flash EPROM needed
- **SuperSense[®]: deep indoor performance**
 - -160 dBm acquisition, reacquisition and tracking sensitivity
- **Ultra-low power consumption: 50 mW**
 - Long battery times
- **Galileo ready**

Features

- 32 channel acquisition engine
- 18 channel tracking engine
- Assisted GPS and Autonomous GPS operation
 - AssistNow[™] ready
 - Supports RRLP, RRC, OMA/SUPL and proprietary protocols
- Wide clock frequency range
 - XTAL: 19-26 MHz, TCXO 19-40MHz
 - Coverage of all cellphone reference frequencies
- Integrated DC/DC converters enable power-efficient applications with single voltage supply
- Supports SBAS: WAAS, EGNOS and MSAS
- Connectivity: USB, 2 UARTs, SPI, DDC
- RoHS compliant (lead-free)

*your position
is our focus*



Receiver Performance Data

Receiver Type	L1 frequency GPS C/A code Galileo Open Service (with upgrade) Supports SBAS: WAAS, EGNOS, MSAS	
Max. Update Rate	4 Hz	
Accuracy	Position	2.5 m CEP
	SBAS	2.0 m CEP ¹
Acquisition	Open sky ²	Indoor ³
	Cold starts	29 s
	Aided starts:	<1 s 10 s
	Hot starts:	<1 s 10 s
	Reacquisition:	<1 s 10 s
Sensitivity	Acquisition and Reacquisition:	-160 dBm
	Tracking:	-160 dBm
	Cold starts:	-145 dBm
Multipath Suppression	Intelligent multipath detection and suppression	
GPS Protocols	NMEA, UBX Binary	
	Supports protocol mixing over same serial port	
A-GPS Assistance Data Standards	UMTS / GSM:	3GPP TS 25.331 RRC 3GPP TS 44.031 RRLP
	CDMA:	3GPP2 C.S0022-0-1
	OMA SUPL	
A-GPS Performance Standards	USA (FCC)	E-911 Phase II
	UMTS / GSM:	3GPP TS 25.171
	CDMA:	TIA.916
Operational Limits	Altitude	18,000 m
	Velocity	515 m/s
	One of the limits may be exceeded but not both.	

¹ Depends on accuracy of correction data provided by the DGPS or SBAS service

² Open sky: All SV –144 dBm or higher

³ Indoor: SV: –155 dBm

RF Functionality

LNA	Built-in (no external LNA required)	
Overall noise figure	2.5 dB (LNA + RF + digital part combined)	
Architecture	Low IF: 3 MHz I and Q	
XTALS	TCXO:	19 – 40 MHz or
	XTAL:	19 – 26 MHz
	RTC XTAL:	32.768 kHz
Synthesizer	Fractional N	

Digital Functionality

Receiver Architecture	32 acquisition channels > 1,000,000 effective correlators	
	18 high-resolution tracking channels	
Processor	ARM7TDMI-S Core	
Memory	ROM	384 K Bytes
	RAM	128 K Bytes
	Backup RAM	4 K Bytes
OTP	32 bits One-Time Programmable memory for device configuration	
External Memory Interf. (BGA only)	Data width:	16 bits
	Address space:	3 x 4 M Bytes
Serial Interfaces	USB Device:	V2.0, 12 Mbit/s Full Speed
	UARTs:	2
	SPI:	1
	DDC (Display Data Channel, I2C compatible): 2 Master / Slaves	
General-Purpose I/O Ports	Package:	BGA 56 Pin QFN
	GPIOs:	22 I/O, 3 In 21 I/O, 3 In
	Voltage range:	1.2 – 3.3 V
Antenna Supervision	Short and open circuit detection supported with external circuit	

Electrical Data

Supply Voltages	Single voltages supply:	1.8 – 4.8 V
	Integrated LDO and DC/DC converter for efficient power management	
Power Consumption	50 mW (tracking & navigating)	
Backup Supply	Voltage range:	1.3 – 4.8 V
	Current:	25 uA

Environmental Data

Operating Temp.	-25°C to 70°C
------------------------	---------------

Packages

Single Package	56 Pin QFN, 8 x 8 x 0.9 mm
Chipset	RF: 24 Pin QFN, 4 x 4 x 0.9 mm BB: 100 Pin BGA, 9 x 9 x 1 mm

Ordering Information

UBX-G5010-A00-ST	u-blox 5 Single Chip GPS Receiver, 56 Pin QFN
UBX-G5000-A00-BT	u-blox 5 Baseband Processor 100 pin BGA
UBX-G0010-A00-QT	u-blox 5 RF Front-End, 24 pin QFN

Parts of this product are patent protected.

Schedule: Sampling in Q1 2007

The specifications in this document are subject to change at u-blox' discretion. u-blox assumes no responsibility for any claims or damages arising out of the use of this document, or from the use of products and services mentioned in this document, including but not limited to claims or damages based on infringement of patents, copyrights or other intellectual property rights. u-blox makes no warranties, either expressed or implied with respect to the information and specifications contained in this document. u-blox does not support any applications in connection with active weapon systems, ammunition, life support and commercial aircraft. Performance characteristics listed in this document are estimates only and do not constitute a warranty or guarantee of product performance. The copying, distribution and utilization of this document as well as the communication of its contents to others without expressed authorization is prohibited. Offenders will be held liable for the payment of damages. All rights reserved, in particular the right to carry out patent, utility model and ornamental design registrations.

u-blox, the u-blox logo, the TIM type GPS module, Antaris, SuperSense, "your position is our focus", NavLox, u-center, AssistNow, FixNow and EK6 are (registered) trademarks of u-blox AG. The u-blox software as well as the design of the LEA type modules is protected by intellectual property rights in Switzerland and abroad. Further information available at info@u-blox.com.